

### CHTBS Hard Top Brushing Station

Work station for achieving used and vintage worn look by brushing specific zones on denim and wovnen cotton fabric.

- Ergonomically designed
- Fast and easily handled, requires only one operator
- Improves material quality



Changeable leg adaptor (4 standard)

Changeable Jacket adaptor (2 standard)

Changeable Arm adaptor (2 standard)

Lamp (standard)

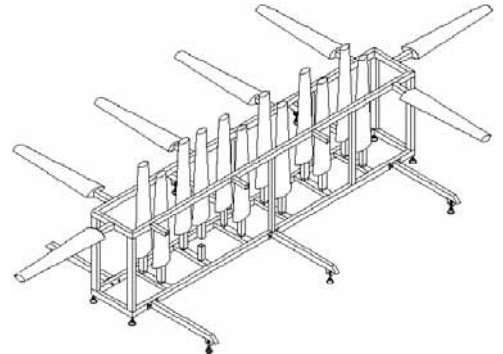
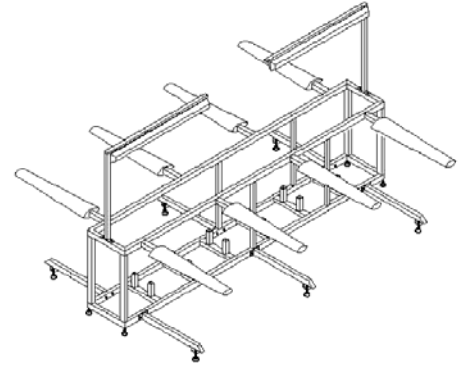

Technical Specifications	
Overall machine height	205 cm.
Overall machine width x depth	211 x 211 cm.
Overall machine weight	60 Kg.
Power Consumption	50 W
Electrical requirement	220V - 240V AC 50Hz
Production Rate	1000 pcs. / 8 hrs.