

Fabric Inspection Machines

CDK6 Woven Fabric Inspection and Manual Picking Machine

Inspection and high speed measuring machine with data collection and analysis system to handle a wide range of rolled woven materials. This system can be supplied to operate from roll to roll, or with various other fabric input and output options.

- Ergonomically designed
- Fast and easily handled, requires only one operator
- Improves material quality
- Synchronizes production processes
- Provides objective process quality reporting
- Accurately measures rolls
- Reduces administration

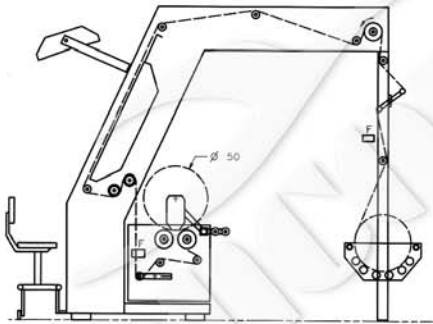

Simple fabric input control

Fabric input controlled from free running rollers for simple and affective control.

End of roll automatic stop sensor - For next roll joining

This will allow for efficient continuous inspection, from roll to roll.

Full width fabric inspection - With 45 deg. fixed angle inspection screen

Fabric can be examined with the aid of different viewing and lighting options.

Accurate fabric length and optional weight measurements

Fabric roll length and weight can be taken using industrial standard measuring systems with digital readouts to give consistent fabric roll assessments.

Consistent roll output - With twin rewind rollers and roll hardness adjustment

Processed rolls are rewound with the minimum amount of tension and are consistent from roll to roll.

Adjustable tension

Manual adjustable tension of fabric when rewinding.

Data collection and analysis system - With fabric fault tagging

100% fabric inspection with simple push-button accurate fault logging, roll length and weight measurement allowing for accurate fabric roll analysis and printout.

Technical Specifications	
Speed	0 to 50 meters / minute
Fabric width	1.8 - 4.0 meters
Standard roll diameter	50 cm
Standard roll weight	100Kg
Overall machine height	245cm
Overall machine width x depth	250 - 450 x 380cm
Overall machine weight	1000Kg
Motor Count	3 AC
Electrical requirement	220V - 240V AC 50Hz

*** Concorde is a registered Trade Mark of Cihan Makina A.S. ***

www.cihanmakina.com / cihan@cihanmakina.com - www.concorde-machines.com / concorde@concorde-machines.com

Head Office: Tekstilkent Koza Plaza A Blok 25.Kat NO: 96 34235 Esenler, Istanbul, TURKEY Tel: +90-212-438 42 50 (Pbx) Fax: +90-212-438 42 40

Factory: Organize Sanayi Bolgesi, 4. Cadde No:8 26110 Eskisehir, Turkey Tel: +90-222-236 00 64 +90-222-236 13 80/ 81/82/ 83

Fax: +90-222-236 03 48 E-mail: fabrika@cihanmakina.com

*** Since 1950 ***